



passivSYSTEMS®

V3.0 PAS-MMSP-008
08 October 2020

PassivLiving Installation Guide

Heat Pump Monitoring with MMSP - BB (V2)



passivSYSTEMS®

Installation Information

This MMSP service provides MMSP monitoring using the broadband connected PassivLiving hub.

This MMSP service includes:

- 1 x PassivLiving hub (PL-HB2-ZW) with power supply and wall mounting bracket
- 1 x Secure Temperature Sensor "TEMP-1"
- 1 x Eastron SDM630 "HP-1" heat pump electricity meter
- 1 x FTDI USB RS485 1.8m cable for meter communications
- 1 x Customer leave behind including activation code and Hub ID sticker

To successfully complete the installation at the home the following are prerequisites:

- Permanent internet connection, the PassivLiving hub is ideally wired directly to the router.
- Mains 230v socket to power the PassivLiving hub. NB: This will act as a disconnection point and should be easily accessible.
- A sub-consumer unit to centralise the power for the heat pump installation and to accommodate DIN rail electricity meter (4 slots) and normal breakers and isolation switch.

IMPORTANT: Installation should only be carried out by a qualified installer according to the current IET Wiring Regulations. The PassivLiving hub should only be installed indoors or in a weather protected location such as a garage or outbuilding.



Installation Information - continued

Prerequisites continued:

- Shielded twisted pair cable to connect the meter's communication connections e.g. Farnell #2481157
<https://uk.farnell.com/pro-power/pp000867/screened-cable-2pr-22-awg-pe-50m/dp/2481157>
- Sontex Heat meter, configured for 1Whr reporting and Glycol percentage (if applicable) with Sontex RS485 communication module and power supply.
NB. The order SKU must be for a heat pump NOT a boiler e.g.
 - SON0440MMSP7
 - SON0449MMSP9
 - SON0449MMSP11

NOTE: If the electricity meter or the heat meter is NOT labelled they should be rejected, as their configuration is unknown.

For the installation to be Ofgem compliant, it is essential the electricity meter is installed at the correct metering points:

- The heat pump electricity meter must cover the entire electrical load of the heat pump installation.
- If present, the hot water immersion element associated with the heat pump must also be metered. The metered load must account only for the immersion and not additional auxiliary loads e.g. pumps and valves.

The PassivLiving hub can be positioned in the following locations:

- Next to the household's internet router.

Implications: Route the FTDI USB RS485 cable to a suitable enclosure e.g. pattress box. Extend the cable with a shielded twisted pair cable to reach the electricity meter. The cable shielding must be earthed in the sub-consumer unit.

- Within 1.5m of the sub-consumer unit housing the electricity meter, as this is the first connection point for the communication cable.

Implications: The PassivLiving hub requires a reliable internet connection, ideally via a wired ethernet cable.

Schematic overview

Below is a basic schematic giving an overview of the connection between the home, the heating system and the MMSP system.

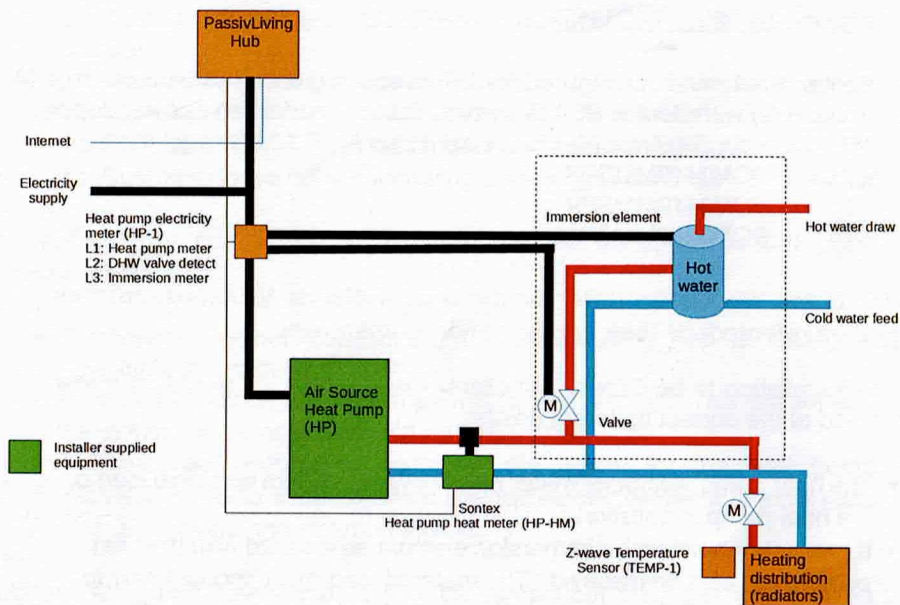

Schematic overview: Communication connections

Below is a schematic giving an overview of the communication connections between the devices.

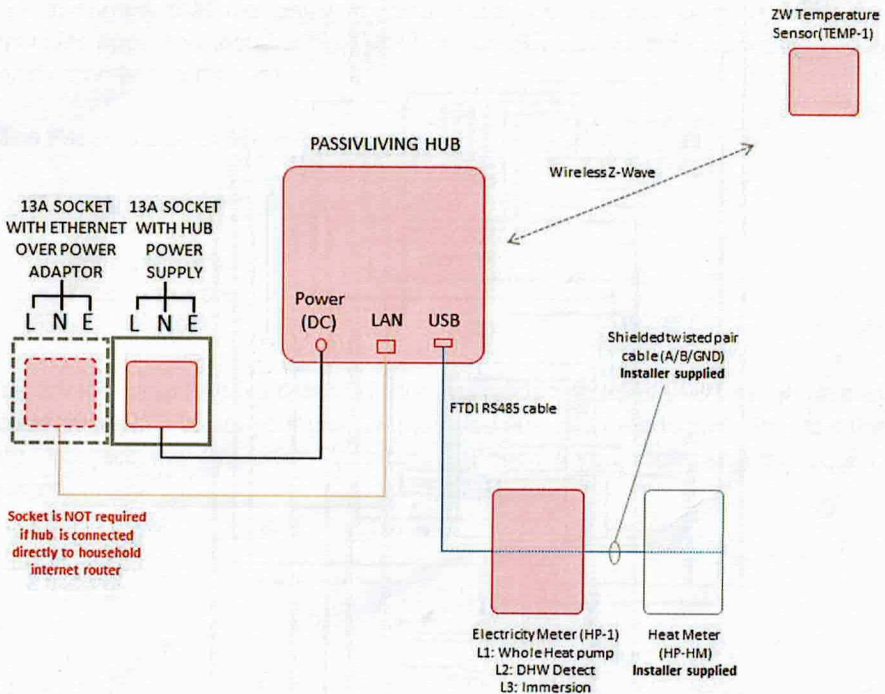



passivSYSTEMS®

Schematic: Mains electrical connections

The diagram below details the mains electrical connections between the components of the system.

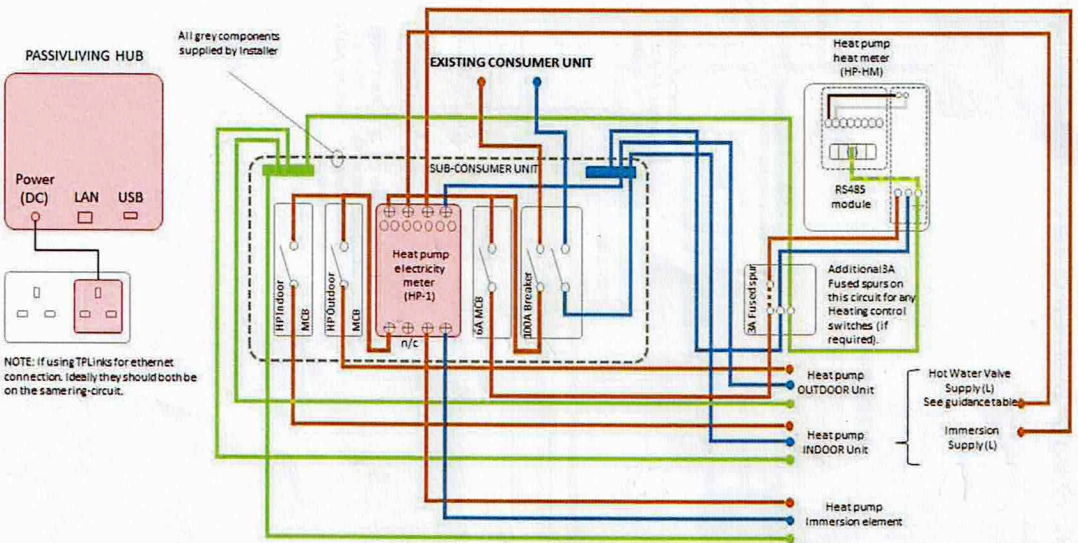



passivSYSTEMS®

Installation order

Installing the system is performed in 2 stages:

- The physical installation of the components, wiring, etc.
- Commissioning the system using the PassivPro installer app.

It's important that the physical installation is completed prior to using the installer app. The installer app will link the devices to the PassivLiving Hub and commission the system.

The Passiv installer app is found at:

passiv.pro/install To login, you will need:

- Your username
- Your password

You should already have received an email advising you of your username and containing a link to set your password. If you are unable to login to the installer app, contact the PassivPro administrator within your company to request access.

Installing the PassivLiving Hub

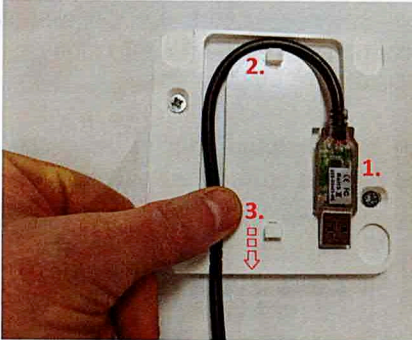

- Affix the bracket to the wall. Place the cable in the guide (1) with the label upwards
- Guide the cable (2) within the cable channel
- Press the cable FIRMLY into the cable clamp (3), starting at the top. Repeat, working downwards, until the cable is fully inserted

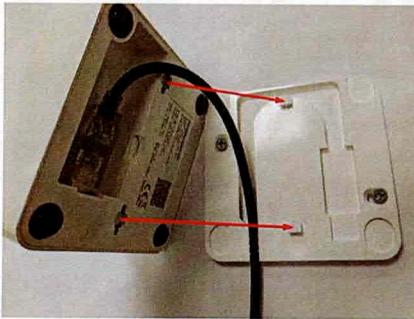

- Carefully insert the USB plug into the PassivLiving Hub
- Ensure the USB cable follows the cable channel
- Centrally align the Hub on the wall bracket, 5mm higher than the wall bracket. The Hub will fit snugly against the wall bracket

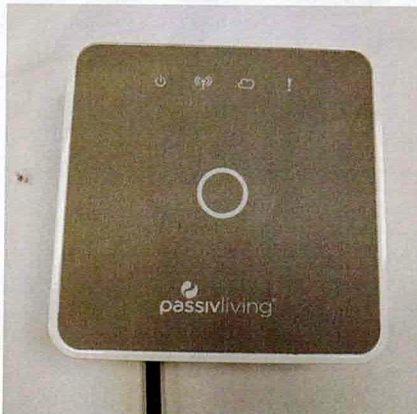

- Carefully slide the Hub downward to lock into place
- Connect ethernet and power cables
- Cable-clip all cables to prevent accidental disconnection



passivSYSTEMS®

Ethernet/internet connection

In order for the MMSP system to report data to the PassivLiving online portal, the PassivLiving hub must be connected to the internet.

The PassivLiving hub is provided with a 1.8m ethernet cable which must be connected from the hub to the customer's internet router. This can be done by either:

- **(RECOMMENDED)** If cable routing permits, connect directly to the internet router (may require longer ethernet cable)
- Alternatively, use Ethernet over Powerline (EoP) adaptors (installer supplied) such as these:



Connect one to the customer's internet router, and the other close to the PassivLiving hub. Ideally, the two adaptors should be on the same ring circuit for reliable communication.

Eastron SDM630 heat pump electricity meter (HP-1) mains wiring

The Eastron SDM630 meter performs several roles:

- (L1) measures the entire energy consumption of the heat pump. This electrical load MUST include the immersion electrical load (if present)
- (L2) measures the voltage to the hot water valve. (L2)_{in} is connected to the live supply for the hot water valve, such that it recognises when the valve is being activated. Please refer to the connection guidance table for specific heat pump connection. No connection is required on (L2)_{out}
- (L3) If an immersion element is fitted and controlled by the heat pump, the live cable to the immersion element from the heat pump must be fed through (L3) and then to the immersion element. This enables the system to calculate the heat pump efficiency correctly.

See diagram below for details on how to wire.

Electricity Meter (Eastron):

Communication cable USB FTDI RS485 cable

- Yellow (-) (B)
- Orange (+) (A)
- Black (GND) (G)

Communication Shielded cable

- White (-) (B)
- Green (+) (A)
- Black (GND) (G)

Note: The SDM630 meter is supplied with a COMMUNICATION SHIELD. This shield must be fitted for safety purposes and protection of connected communication equipment.

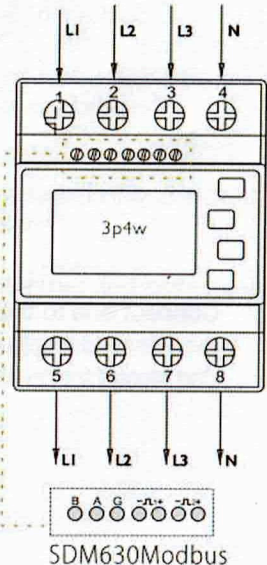



Eastron SDM630 heat pump electricity meter (HP-1) mains wiring - continued

Below is the guidance table for connecting the Eastron SDM630 meter (L2) to monitor when the hot water valve is activated.

Note: The table is for guidance only. The installer has responsibility to confirm the connections for the model of heat pump installed.

Manufacturer	Unit/Model	Live (brown) connection
Samsung	Indoor Unit/EHS Mono	B17
Daikin	LT Split/Hybrid Monobloc	X2M 10 (3-way valve NO) X2M 3
Hitachi	Indoor Unit/Yataki	32 C (3WV - DHW)
Panasonic	Mono H Series	CN1 Open (3-way valve)
Vaillant	aroTHERM	UV1 (Auf)
Mitsubishi	Ecodan (3-way valve)	TBO.2.5
Grant	Aerona	EP002 (2) DHW
NIBE	F2040	AA2-X4:3
LG	Gen 3 R32 Mono	T1:9

This SDM630 meter uses a single neutral. However, several circuits are metered by the SDM630, these circuits need to be protected by a shared RCD.

Eastron SDM630 heat pump electricity meter (HP-1) comms wiring

The Eastron SDM630 meter is the first device on the communication wiring chain.

Please see the diagram below a detailed comms wiring diagram for the system.

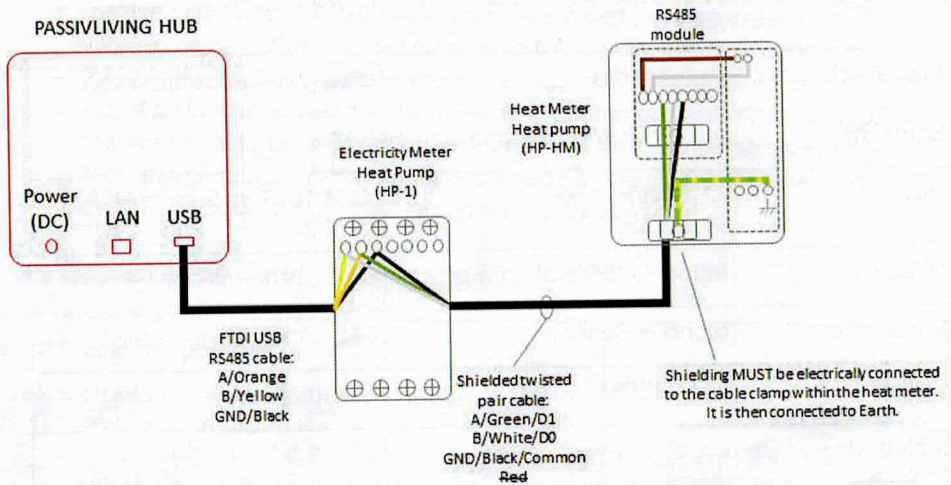

System communications wiring diagram

The previous page contains a detailed image of the heat pump electricity meter including its communication connections.

To make a reliable connection with a pair of wires, which is required to continue the communication wiring chain. Strip back double the connector length on each core, twist together and then fold over the exposed cores to half their length of the exposed cable, insert in the connector and tighten. Gently tug-test to ensure a sound connection.

Wiring the Sontex heat pump heat meter RS485 module

The Sontex heat pump heat meter (HP-HM) is connected to the PassivLiving Hub via the heat pump electricity meter (HP-1) using shielded cable (see page 2).

Please see below for a photo of both the RS485 module on the left and mains power supply, on the right. **Check the white cable is connected to 0V and the brown connected to +12VDC on the RS485 module.**

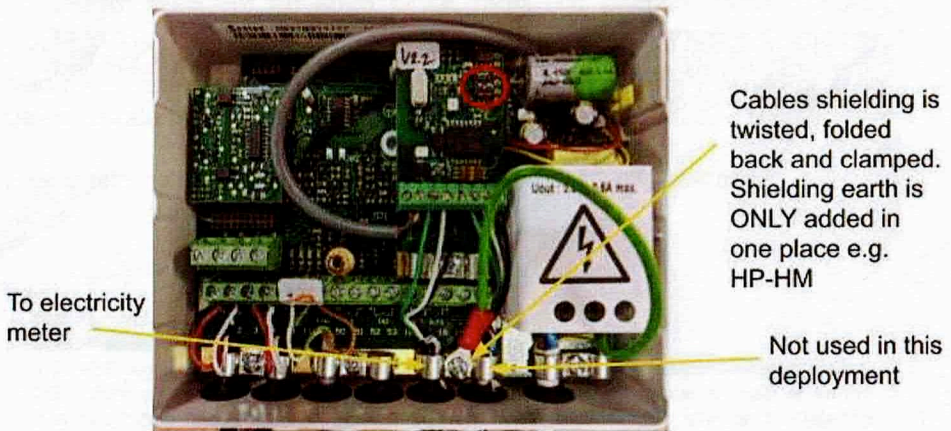

Sontex heat meter with RS485 module and mains supply

- Ensure the meter is labelled as HP-HM for the heat pump
- Ensure only DIP switch 2 (middle switch) circled in red is ON. DIP switch 1 & 3 must be OFF to achieve the 9600 baud rate
- There are two pairs of communication connections, which are interconnected. With this deployment only one is needed as this is the last device in the communication chain (see page 11).
- Feed the shielded cable carefully through the black rubber grommets provided at the bottom of the heat meter.
- Connect "D1" to the green core (shielded cable), which is connected to the orange core "A" of the RS485 cable in the electricity meter (HP-1)



passivSYSTEMS®

- Connect “D0” to the white core (shielded cable), which is connected to the yellow core “B” of the RS485 cable in the electricity meter (HP-1)
- Connect Common the black core (shielded cable), which is connected to the black core of the RS485 cable in the electricity meter (HP-1)
- The cable shielding must be folded back over the outer cable insulation and clamped by the metal clamp within the heat meter. This secures the cable and electrically connects the shielding.
- Use a ring crimp and earth cable to connect the RS485 module metal clamp to the earth connection on the power supply (see page 11)
- Ensure all screws have good contact with the wire and are tight by performing a tug test.

NOTE: When placing the front panel back on the heat meter, ensure the front panel is aligned and level with the back body of the unit. If this is not done, connector pins can become bent and do not align or connect properly, causing a faulty meter.



Installing the heat meter temperature probes

For the heat meter to accurately measure the energy generated by the heat pump, it's essential the temperature probes are correctly installed. You must ensure:

- The probes are in the path of the heating fluid flow
- Both probes are installed either directly in the heating fluid or in protective pockets
- The measuring tip of the temperature probe must be in the centre of the pipe cross section
- The flow (red) and the return (blue) temperature probes are correctly placed in the heating system

If the temperature probes do not respond promptly and accurately to the heat fluid temperature, the efficiency data generated by the PassivLiving Portal will be inaccurate and invalidate the data collected and presented.

Please refer to the Sontex installation guidelines for further details.

Picture: Example 22mm compression T-piece with 1/2" BSP female fitting.
NB. Samsung EHS heat pumps typically need 28mm pipe fittings



Picture: 1/2" BSP temperature pocket (supplied with Sontex 440) inserted in the T-piece

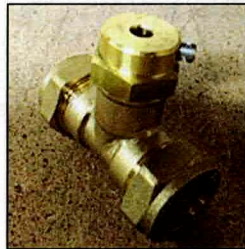

Picture: The temperature probe pocket is in the full flow of the heating fluid



Installing the Temperature Sensor (TEMP-1)

Find a suitable location for the temperature sensor in a room that is heated by the heat pump (the main living area is best, if possible).

Insert the batteries and ensure they are secure.

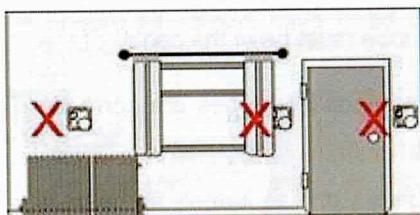

- Where possible, the mounting location should be approx. 1.5m from the floor.

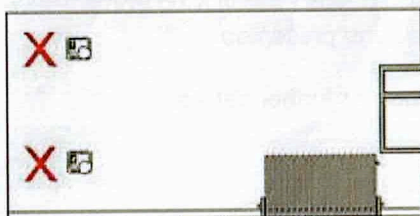

- It should also be positioned away from heat sources, such as radiators, draughts and direct sunlight.

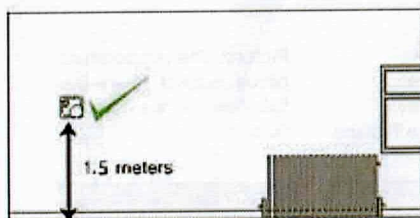

- It should be fixed to a wall not covered by anything, such as curtains, to allow a free flow of air around it.

Fix the temperature sensor to the wall using the supplied bracket.



Commissioning using the installer app

To join the devices to the PassivLiving Hub:

- Ensure all devices are wired correctly and powered
- Login to the installer app
- Select the property address you are installing at from the drop-down list. If the address is not available, contact the PassivPro administrator within your company.
- Follow the directions given by the installer app.

Joining the wired devices:

- The installer app will step through each of the meters confirming they can communicate.
- If a meter is not recognised please check the meter's wiring and Modbus address is correct via the device's menu. Please consult the device's installation guide for further details.

Joining the temperature sensor

- Click the 'Join' button on the Installer App and wait for "Ready for device joining..." to show on the screen.
- Press the small black button in the bottom left-hand corner on the back of the device for at least 1 second. A small red LED will flash twice after the button is released, if joining has been successful.
- If joining fails then attempt an 'Exclude' to fully remove the connection to the device. Then retry the 'Join' process using the same steps above.



passivSYSTEMS®

Completing the installation

When the installation is complete and all the devices have been successfully joined, the installer app will automatically configure the Hub with the correct settings and display all the joined devices, and their online status.

If the Hub has lost contact with a device, subsequent to it being joined, this will be shown as offline and the installer will be advised to investigate the cause, and re-join if necessary.

To confirm a successful installation and check the system is functioning as expected, call PassivSystems Support. This is recommended for initial installations only.

PassivSystems Support: 0333 006 2934



passivSYSTEMS®

Final Checks

Before leaving the site, please ensure that the below areas are complete:

- For initial installations: A call has been made to PassivSystems Support, who have confirmed that the installation is working as expected. Call PassivSystems on 0333 006 2934.
- The additional sticker containing the Hub ID and Activation code has been affixed to the customer's 'PassivLiving MMSP Broadband Service' information sheet.
- Contact details for the installer or installation company have been added to the customer's 'PassivLiving MMSP Broadband Service' information sheet in the appropriate space under 'Additional Help'.
- The homeowner has been set up with access to the PassivLiving portal and is able to login successfully.

Declaration of Conformity

Declaration of Conformity

We *PassivSystems Limited of Benyon House, Newbury Business Park, Newbury, RG14 2PZ* declare under our sole responsibility that the product:

Description	Model name	Product Code
Z-wave enabled controller	PAS1 Hub	PL-HB2-ZW

to which this declaration relates are in conformity with all the essential requirements of Radio Equipment Directive 2014/53/EU and RoHS Directive 2011/65/EU

The following harmonised standards have been applied with respect to these products:

EN 60950-1:2006/ A2:2013

EN 62311:2008

EN 55032:2015

EN 55024:2010

EN 301 489-1 V2.2.0

EN 301 489-17 V3.2.0

EN 300 220-2 V3.1.1

EN 50581:2012

Authorised Person

[Signature] *Fraser Harding*

[Name] Fraser Harding

[Position] VP Engineering

[Date] 3rd June 2020