

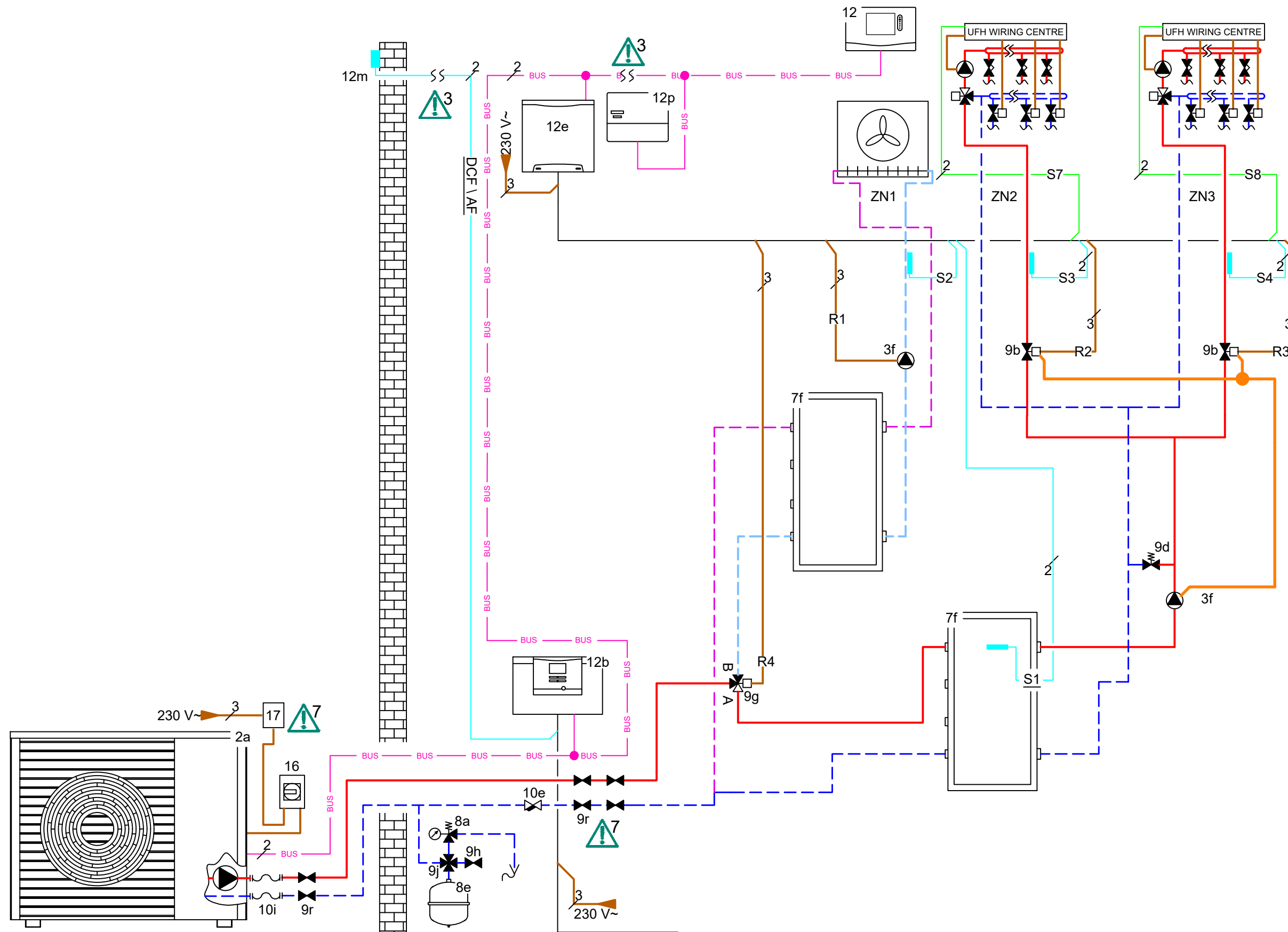

- See page 2 for detailed wiring.
- 1. See page 3 for relevant controller system configuration settings.
 - 3. Controls and outdoor sensor can be wired or wireless.
 - 4. Link required (not factory fitted).

- 7. Optional for heat meters.
- 8. Coil flow rate MUST meet requirements of **COMBINED** HP flow rates
- 15. At least 1 radiator required to be open at ALL times to allow bypass / thermostat zone reference.



30713-1002

-  -See page 2 for detailed wiring.
1. See page 3 for relevant controller system configuration settings.
 3. Controls and outdoor sensor can be wired or wireless.
 4. Link required (not factory fitted).

7. Optional for heat meters.
8. Coil flow rate MUST meet requirements of **COMBINED** HP flow rates
15. At least 1 radiator required to be open at ALL times to allow bypass / thermostat zone reference.

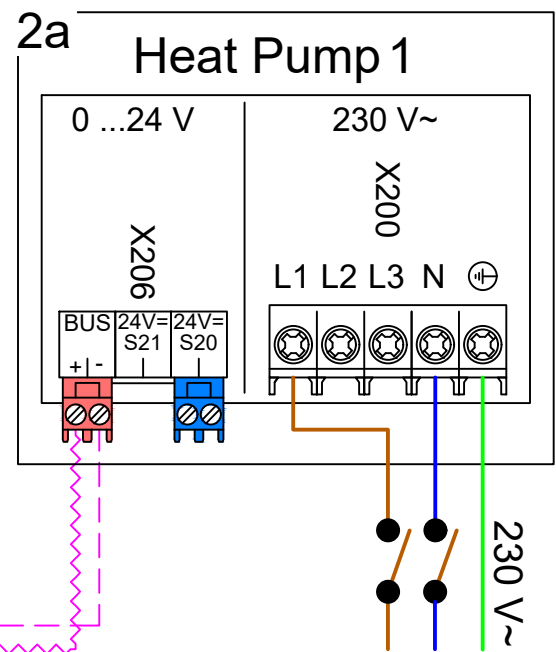
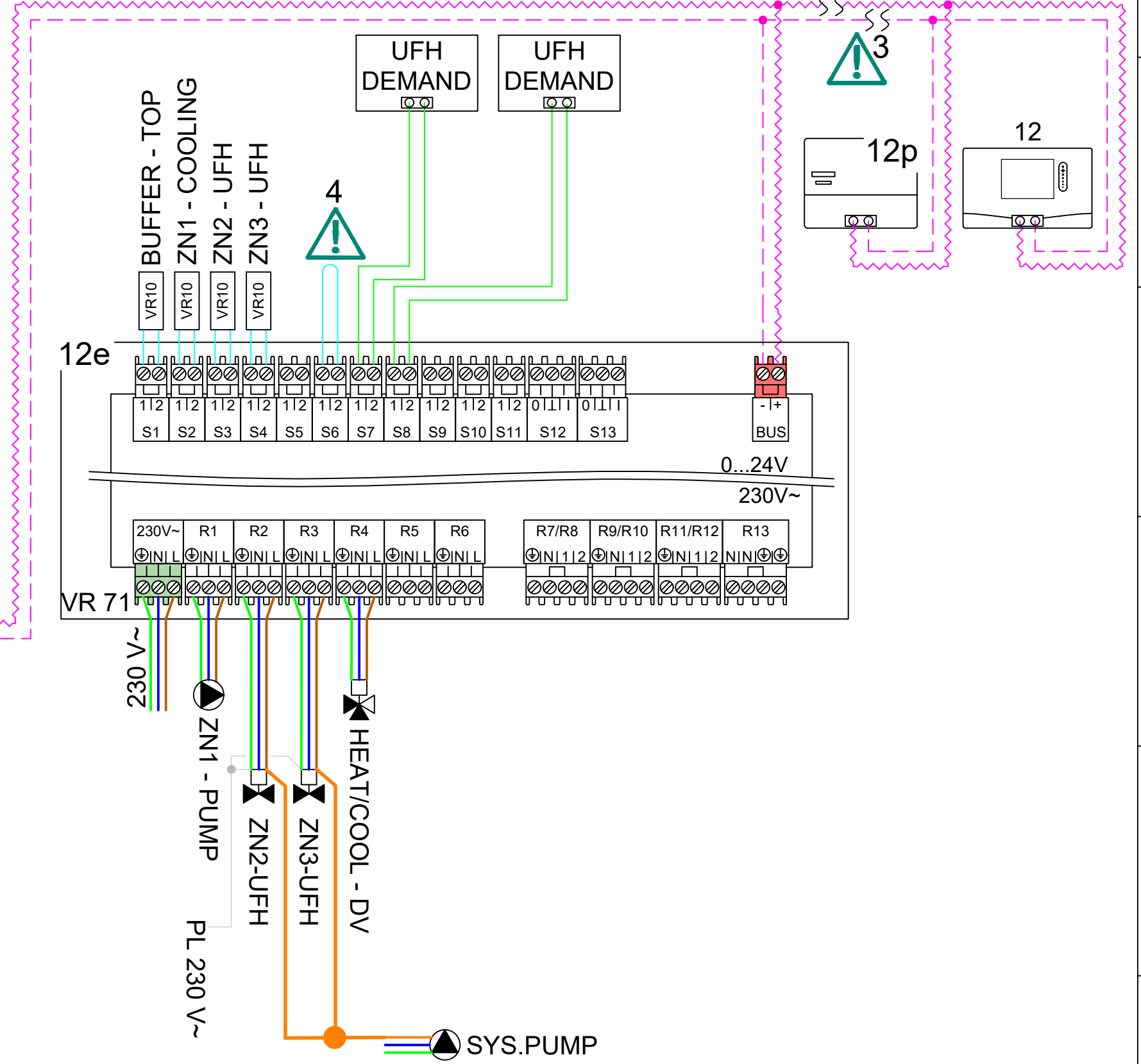
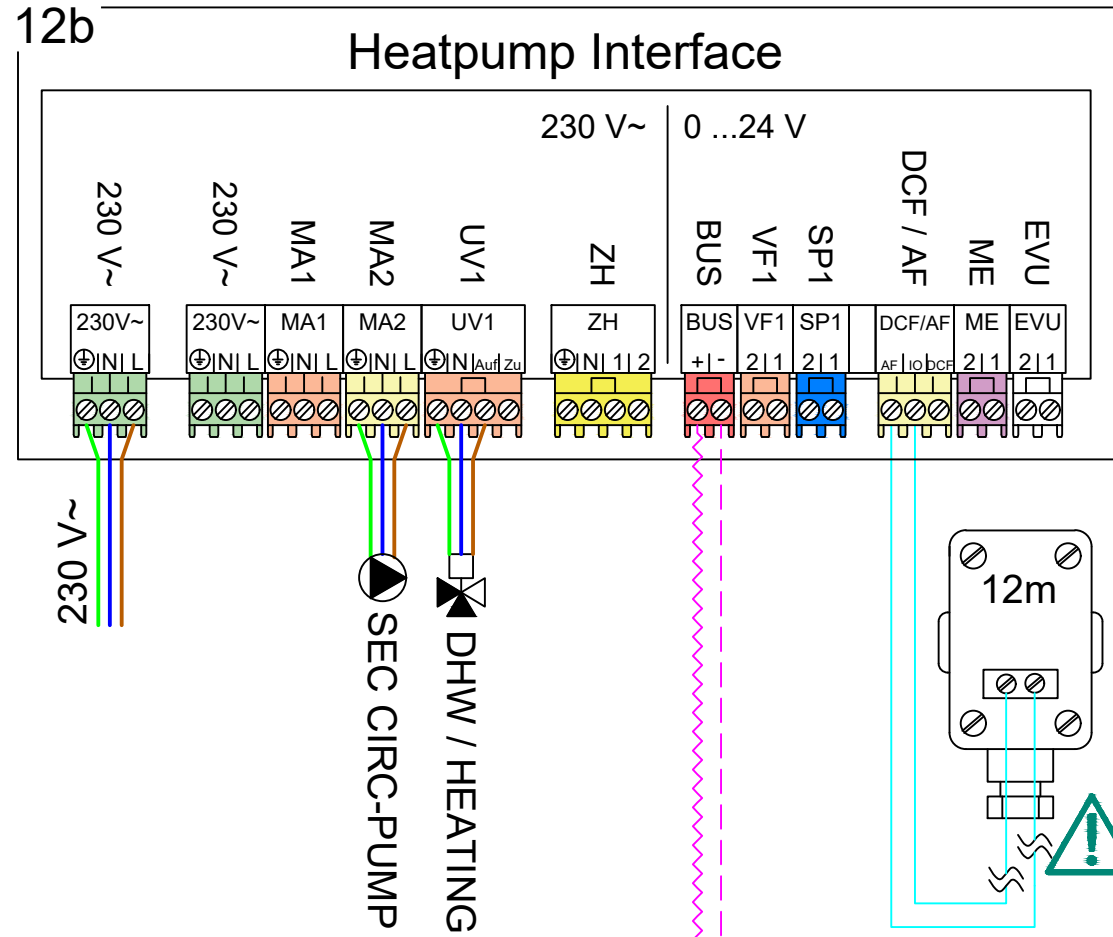

Vaillant Group disclaimer: This drawing is supplied for information and general guidance only. No responsibility is accepted for any errors or omissions contained within or for any cost incurred in rectifying any work relating to it.

Drawn: A.RICE
04/10/2022 REV: A

Appliance(s): 1x aroTHERM Mono, Buffer 40L
Control(s): sensoCOMFORT

HTG. Circuit(s): 1x Cooling - Direct, 2x UFH - 3rd Party, ----
Domestic Hot Water: ----

30713-1002

Terms and Conditions for Vaillant Schematic Diagrams



PLEASE NOTE THAT THE DIAGRAM PROVIDED IS FOR GENERAL INFORMATION PURPOSES ONLY. THE ADVICE AND INPUT OF A PROFESSIONAL, QUALIFIED, GAS SAFE / MCS INSTALLER MUST BE SOUGHT. VAILLANT IS NOT RESPONSIBLE FOR INSTALLATIONS OR FOR THE PROFESSIONAL DESIGN OF THE SYSTEM.

- All applicable laws and regulations must be followed.
- The Diagram may be subject to alteration at any time.
- Vaillant is not responsible for any inaccuracies or omissions in the information and drawings provided to it and upon which it relies when constructing the diagrams.
- Any reproduction of the design must have the prior permission of Vaillant.
- During the planning, design, installation and later use of the system, all operating instructions must be followed.
- In no circumstances shall Vaillant be liable to you or any other third parties for any loss or damage (including, without limitation, damage for loss of business or loss of profits) arising directly or indirectly from your use of or inability to use, this diagram.
- Vaillant makes no representations or warranties of any kind, express or implied about the completeness, accuracy, reliability or suitability of the diagram for any purpose. Any reliance you place on the diagram is therefore strictly at your own risk.
- These disclaimers and exclusions shall be governed by and construed in accordance with English law.

- 02 aroTHERM Monoblock
- 03f General Pump
- 07f 45L Buffer
- 08a Pressure Relief Valve
- 08e Heating / DHW Expansion Vessel
- 09b Zone Valve
- 09d Bypass Valve
- 09g Diverter Valve
- 09h Fill / Drain Valve
- 09j Expansion Vessel Service Valve
- 09r Isolation Valve
- 10e Y Strainer
- 10i Flexible Connection
- 12 sensoCOMFORT
- 12b Heat Pump Interface
- 12e Wiring Centre - VR 71
- 12m Outdoor Temperature Sensor
- 12p Wireless Reciever
- 16 Rotary Isolator
- 17 Electric Meter

sensoCOMFORT / VRC 700 System Configuration

Not all settings are displayed, commissioning of the controller should be done diligently; going through each adjustable option with consideration to the property and system requirements.

Setting	Value	Setting	Value
Installation		Circuit 2	
Adapt. heat curve:	Deactivated	Circuit type:	Heating
Hybrid manager:	Bivalence pt	OT switch-off threshold:	30°
Heating bivalence point:	-20°	Heat curve:	**Site specific
DHW bivalence point:	-20°	Min. target flow temperature:	15°
Alternative point:	Off	Max. target flow temperature:	45°
Back-up boiler:	Off	Set-back mode:	Eco
Conf. ext. input:	Open, deactiv.	Room temp. mod.:	Inactive
Actuation reversal:	On	Circuit 3	
Basic system diagram config.		Circuit type:	Heating
Basic system diagram code:	16	OT switch-off threshold:	30°
FM5 configuration:	3	Heat curve:	**Site specific
FM5 MO:	Cooling Signal	Min. target flow temperature:	15°
HP control module configuration		Max. target flow temperature:	45°
MO 2:	Secondary Circ Pump	Set-back mode:	Eco
Circuit 1		Room temp. mod.:	Inactive
Circuit type:	Heating	Zone 1	
OT switch-off threshold:	10°	Zone activated:	Yes
Heat curve:	0.1	Zone assignment:	Control
Min. target flow temperature:	10°	Zone 2	
Max. target flow temperature:	10°	Zone activated:	Yes
Set-back mode:	Normal	Zone assignment:	No assignmt
Room temp. mod.:	Expanded	Zone 3	
Cooling Possible	Yes	Zone activated:	Yes
		Zone assignment:	No assignmt

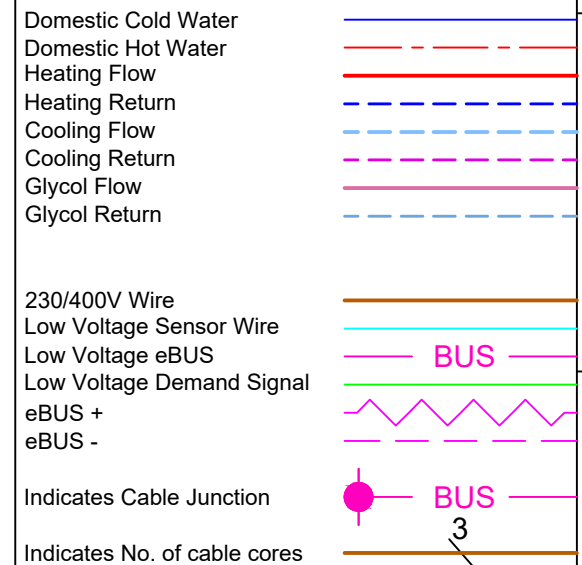

Vaillant Group disclaimer: This drawing is supplied for information and general guidance only. No responsibility is accepted for any errors or omissions contained within or for any cost incurred in rectifying any work relating to it.

Drawn: A.RICE

Appliance(s): 1x aroTHERM Mono, Buffer 40L

HTG. Circuit(s): 1x Cooling - Direct, 2x UFH - 3rd Party, ----

04/10/2022

REV: A

Control(s): sensoCOMFORT

Domestic Hot Water: ----